



CITY OF COUNCIL GROVE • 205 UNION STREET • PO BOX 313

COUNCIL GROVE, KS 66846 • 620-767-5417 • COUNCILGROVE.COM

**City Council Agenda  
July 19, 2022  
5:30 P.M. - City Hall**

WELCOME AND CALL TO ORDER

PLEDGE OF ALLEGIANCE

PUBLIC COMMENT PERIOD

Items not already on the agenda may be brought before the Governing Body. Persons must sign in to be eligible. (Three-minute maximum time limit). After three minutes, items will then be voted on to see whether to place the item on the next agenda.

CONSENT AGENDA:

- Minutes from the Previous meeting:
- Appropriations:
- Lake Cabin Transfer:

Pages 2 – 3

Motion:	Seconded:	Action:	Abstention:	Este. Cost:	Appd.	Cost:
---------	-----------	---------	-------------	-------------	-------	-------

OLD BUSINESS:

- N/A

Motion:	Seconded:	Action:	Abstention:	Este. Cost:	Appd.	Cost:
---------	-----------	---------	-------------	-------------	-------	-------

NEW BUSINESS:

- Water Deposit Adjustment:

Page 4

Motion:	Seconded:	Action:	Abstention:	Este. Cost:	Appd.	Cost:
---------	-----------	---------	-------------	-------------	-------	-------

- City Lake Committee Recommendation:

Pages 5 - 13

Motion:	Seconded:	Action:	Abstention:	Este. Cost:	Appd.	Cost:
---------	-----------	---------	-------------	-------------	-------	-------

- Executive Session: Attorney Client Privilege City Lake

Motion:	Seconded:	Action:	Abstention:	Este. Cost:	Appd.	Cost:
---------	-----------	---------	-------------	-------------	-------	-------

Governing Body Comments:

Adjournment:

City Council Meeting Minutes  
July 5, 2022

**WELCOME AND CALL TO ORDER**

Mayor Debi Schwerdtfeger called the regular City Council Meeting to order. Council members present were Keith Wessel, Jason Booker, Mark Berner, Sean Honer, Larry Siegrist, Sharon Haun also present were City Administrator Nick Jones. Others attending were Marcus Hernandez, Angie Schwerdtfeger, Pastor Billy Kryger, David Cullip,

**PUBLIC COMMENT PERIOD**

Angie Schwerdtfeger representing Pride ask the Council to allow the Farmers Market to block off parking spaces on S Mission Street. After discussion the Council approved allowing signs to be posted the day of the Farmers Market that read no parking starting at 2pm. A motion was made by Councilperson Sean Honer to approve the request. The motion was seconded by Councilperson Keith Wessel.

**CONSENT AGENDA**

Councilperson Jason Booker made a motion to approve the Consent Agenda as presented in the packet. Councilperson Sharon Haun seconded the motion. Motion Carried 6 – 0. The consent agenda consisted of:

- June 21, 2022, Minutes
- June 21, 2022, to Current Appropriations.
- Cabin Transfer: R-13

**OLD BUSINESS**

- **Old Penny's Concrete Plant – Update**

City Administrator Nick Jones updated the Council on the progress of crushing the old concrete. Administrator Jones told the Council that approximately 3,000 tons of concrete has been crushed and the plan is to move it to the lake in the Fall.

**NEW BUSINESS**

- **Water Tower Fence**

City Administrator Nick Jones said that work will begin next month on the city water tower and with the addition of a ladder that he would like to have the property surveyed by GEOTEC out of Emporia and have a fence installed. Councilperson Sean Honer asked if the Boy Scout Cabin would be fenced in as well. Administrator Jones said it would likely be fenced in to protect it from vandalism. After discussion Councilperson Jason Booker made a motion to have GEOTEC do the survey and get priced on fencing. The motion was seconded by Councilperson Keith Wessel. Motion Carried 6 - 0

- **Request for Water Service: Jason & Stephanie Frazier**

Administrator Nick Jones presented a request from Jason and Stephanie Frazier at 621 Pondway located in the County to be annexed to receive city water. Administrator Jones said Utilities Superintendent Derrick Craige there is no issue with installing water service. After discussion a motion was made by Councilperson Sean Honer to approve the request. The motion was seconded by Councilperson Sharon Haun. Motion Carried 6 – 0

- **Executive Session - City Lake**

Mayor Debi Schwerdtfeger asked for a motion to go into Executive Session. A motion was made by Councilperson Keith Wessel to go into executive session for attorney client privilege regarding the City Lake, which included the Mayor, City Council, City Annexation Attorney and City Administrator for 45 minutes. The Motion was seconded by Councilperson Sharon Haun. Motion Carried 4 – 0  
Upon returning to regular session no action was taken.

**GOVERNING BODY COMMENTS**

- Councilperson Jason Booker – said the Fireworks show was awesome and thanked all involved
- Councilperson Mark Berner – Thanked everyone involved with the 4<sup>th</sup> of July event
- Councilperson Keith Wessel – said he echoed the other councilmembers comments
- Councilperson Sean Honer – N/A
- Councilperson Larry Siegrist – N/A
- Councilperson Sharon Haun – reminded everyone about the Gun Fight on the Santa Fe Trail on the 15<sup>th</sup> and 16<sup>th</sup>.
- City Attorney Brian Henderson – Absent

- **City Administrator Nick Jones** – reminder everyone about the budget work study on July 6<sup>th</sup> at 5:30pm in City Hall. Councilperson Keith Wessel made a motion to hold a Budget work study. The motion was seconded by Councilperson Sharon Haun. Motion Carried 6 – 0 Presented a request from Riverbank Brewing Alcohol Events application to sell beer at the Gun Fight on the Santa Fe Trail on Friday July 16<sup>th</sup> starting at 4pm to 11pm. A motion was made by Councilperson Sean Honer to approve the application. The motion was seconded by Councilperson Mark Berner. Motion Carried 6 – 0

Mayor Debi Schwerdtfeger asked for a motion to adjourn. Councilperson Jason Booker made a motion to adjourn. Councilperson Sean Honer seconded the motion. Motion carried 6 – 0

\_\_\_\_\_  
Debi Schwerdtfeger Mayor

ATTEST:

\_\_\_\_\_  
Nick Jones City Administrator

ORDINANCE NO. 1992

AN ORDINANCE SETTING RATES AND POLICIES WITH REGARD TO WATER DEPOSITS BEFORE CONNECTION WITH THE CITY WATER SYSTEM

BE IT ORDAINED BY THE GOVERNING BODY OF THE CITY OF COUNCIL GROVE, KANSAS:

Section 1. WATER DEPOSIT. Before any consumer shall be connected with the water system, he or she shall sign an application or contract for service on forms furnished by the city and shall deposit with the city clerk, in the case of domestic consumers, the sum of \$60.00 or in the case of commercial/industrial consumers, such deposit may be determined by the superintendent of the water works which amount will not be less than the amount of the estimated bill for two months usage of water. The water superintendent may, at any time, require an increase in the deposit made by any residential, commercial or industrial consumer. The amount of any unpaid water bill shall be deducted from the deposit and the unused portion returned to the consumer upon termination of service.

Section 2. RECONNECTION. Should any person who formerly had service, request reconnection to the city water system, any outstanding account to the city for such prior service shall be paid in full prior to reconnection.

Section 3. REPEAL. Section 16-125 of Ordinance 1820 of the ordinances of the City of Council Grove is hereby repealed.

Section 4. EFFECTIVE DATE. This ordinance shall be effective upon its publication in the Council Grove Republican.

PASSED AND APPROVED BY GOVERNING BODY OF THE CITY COUNCIL GROVE ON THIS 10 day of July, 2006.

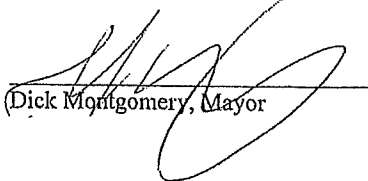
  
\_\_\_\_\_  
(Dick Montgomery, Mayor)

ATTEST:

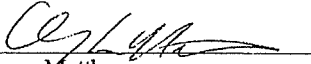
  
\_\_\_\_\_  
Danny Matthews  
City Clerk  
(SEAL)



## CITY LAKE COMMITTEE

City Council Meeting Recommendation, July 19, 2022

1. Recommends the Council approve an installation of water slide.  
Attached is a copy of manufacturer's placement instructions and assembled layout of slide. Along with area view of location.

Charles and Connie Busch, I-17 Cabin 108 Shoreline Drive

The installation will not restrict or interfere with the neighboring cabins or access to the area.

LAKE COMMITTEE: Sean Honer  
Larry Siegrist

CITY INSPECTOR: Dan Drube

**12-663. Installation of slides, diving boards and similar structures.**

(a) PERMIT REQUIRED. No persons shall construct or install any slide, water slide, diving board, or any other similar structure at the Council Grove Lake Park without first having a permit for the approval of such construction and installation from the governing body of the City of Council Grove, Kansas.

(b) PENALTY. Any person violating this section shall be required to remove any such improvement or structure and shall also be subject to a fine of not less than \$100.00 nor more than \$1,000.00.

(Ord. 1942; Code 2019)

# Building Permit Application

## City of Council Grove, Kansas

To be completed by Applicant...

**Job Address** 117 CABI  
108 Shoreline Drive

**Owner**  
Charlie and Connie Busch

Job Address: 117 CABIN 108 Shoreline Drive	
Owner: Charles and Connie Busch	Phone: 785-341-3219
Mailing Address: 5480 W. 63rd Ave	City: Manhattan State: KS Zip: 66503
Contractor: Adams Lumber	License No.: 19 Phone: 620-767-5818
Mailing Address: 203 E. Main	City: Council Grove State: KS Zip: 66846
Use of Building: stationary boat dock	Area (ft <sup>2</sup> ):
Class of Work (circle):	New <input type="checkbox"/> Addition <input checked="" type="checkbox"/> Alteration <input type="checkbox"/> Repair <input type="checkbox"/> Move <input type="checkbox"/> Remove <input type="checkbox"/>
Describe Work: Drive four new 4-1/2" diameter steel pilings into lake bed off shoreline. Weld steel framing and frame with pressure treated wood joists and composite decking, creating new dock areas to the east and west side of existing stationary dock. Installation of a new "Rogue2" series S.R. Smith water slide. (SEE NEXT PAGE FOR NEW STATIONARY LAYOUT AND SLIDE SPECIFICATIONS)	
Valuation of work: \$ 14,000.00	

**NOTICE**

Separate permits are required for electrical, plumbing, mechanical and building. This permit becomes null and void if work or construction authorized is not commenced within 180 days, or if construction or work is suspended or abandoned for a period of 180 days at any time after work is commenced. I hereby certify that I have read and examined this application and know the same to be true and correct. All provisions of laws and ordinances governing this type of work will be complied with whether specified herein or not. The granting of a permit does not presume to give authority to violate or cancel the provisions of any other state or local law regulating construction or the performance of construction.

**Permit not validated until Permit Fee is paid.**

*Taylor R. Adams* 7/16/22

<b>Signature of Contractor or Authorized Agent</b>	<b>Date</b>
<b>Signature of Owner (if owner builder)</b>	<b>Date</b>

OFFICE USE ONLY			
Use Zone:		Code Edition:	
Construction Type:		Occupancy Group:	
Max. Occ. Load		Division:	
No. of Stories:		No. of Dwelling Units:	
No. of Off-Street Parking Spaces		Fire Sprinklers Required:	Yes No

SPECIAL APPROVALS:	REQUIRED: (YES/NO)	RECEIVED: (date)
Zoning Board:		
Health Department:		
Fire Department:		
KS Historical Society:		
KDOT:		
US Army Corps of Engineers		
City Council:		
Other (specify)		

OFFICE USE ONLY	
Special Conditions:	
Permit No.:	Approval Date:
Approved By:	

**PERMIT FEE: \$**



## ROGUE2

# ASSEMBLY AND INSTALLATION INSTRUCTIONS



## WARNING

S.R. SMITH ROGUE2 SLIDES ARE MANUFACTURED FOR INSTALLATION AND USE ON RESIDENTIAL INGROUND SWIMMING POOLS ONLY. THE ROGUE2 IS NEVER TO BE INSTALLED AND USED ON ABOVEGROUND POOLS, ONGROUND POOLS, HOUSEBOATS, BOAT DOCKS, FLOATING DOCKS OR PLATFORMS OR OTHER BODIES OF WATER SUCH AS LAKES, PONDS, RIVERS, ETC.

SRS AUSTRALIA, PTY LTD  
12 Enterprise St  
Richlands QLD 4077  
Australia  
Phone 07 3812 2283 • Fax 07 3812 1187  
[www.srsmith.com/au](http://www.srsmith.com/au)

S.R. SMITH, LLC  
CORPORATE HEADQUARTERS  
P.O. Box 400 • 1017 S.W. Berg Parkway  
Canby, Oregon 97013  
USA  
Phone (503) 266 2231 • Fax (503) 266 4334  
[www.srsmith.com](http://www.srsmith.com)



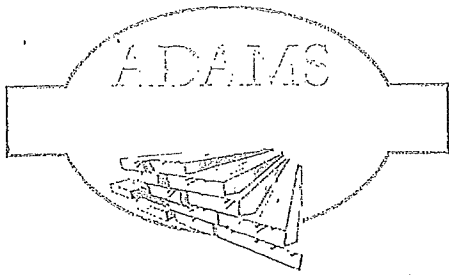

CONSTRUCTION

203 E. MAIN COUNCIL GROVE, KS 66846 620-767-5818

7/6/22  
117 Busch dock extension

note: drawing NOT  
to scale

prospective dock  
OVERVIEW PLAN

page #2 decking layout

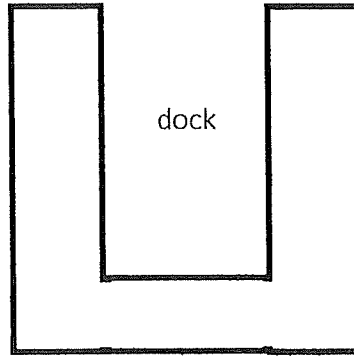

new areas =

steel piling = ○

existing dock =



← gangway

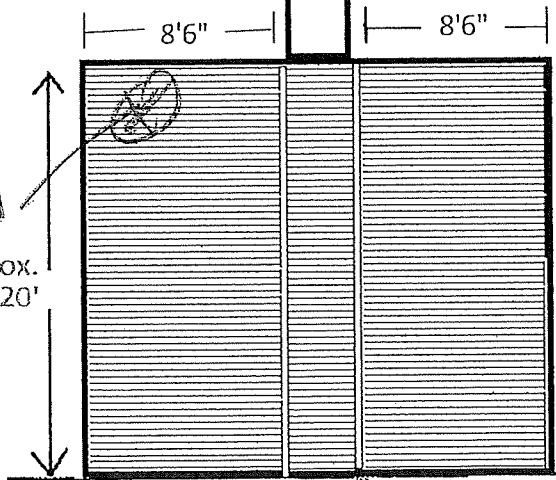

stole  
location  
approx.  
20'

↑  
existing dock

transition/perpendicular  
piece 1 of 2

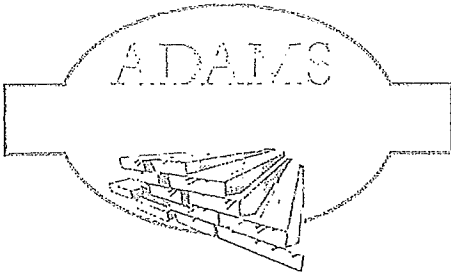

ADAMS  
CONSTRUCTION

203 E. MAIN COUNCIL GROVE, KS 66846 620-767-5818

7/6/2022

117 Busch dock extension

note: drawing NOT  
to scale

**prospective dock**  
OVERVIEW PLAN

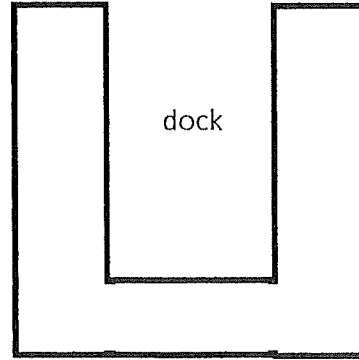

new areas =

steel piling = ○

existing

dock = \_\_\_\_\_

← gangway

8'6" 8'6"

*stair  
breast*

approx.  
20'

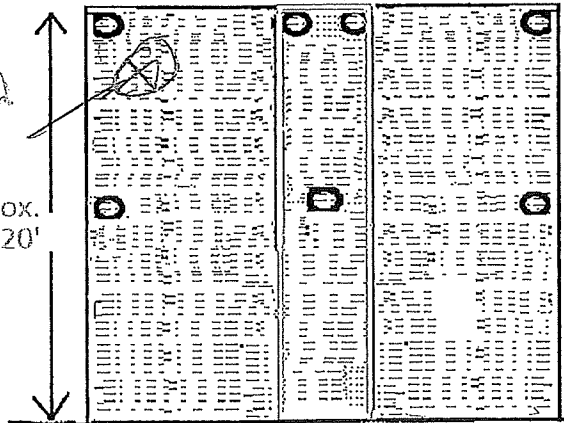

EXISTING SHORELINE

existing dock

6'

### ASSEMBLED ROGUE2 LAYOUT

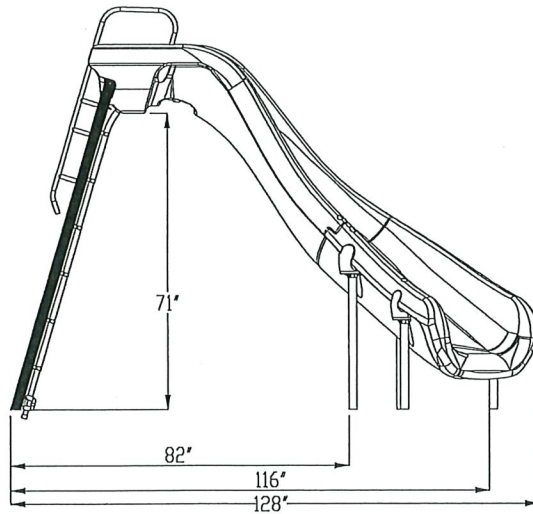
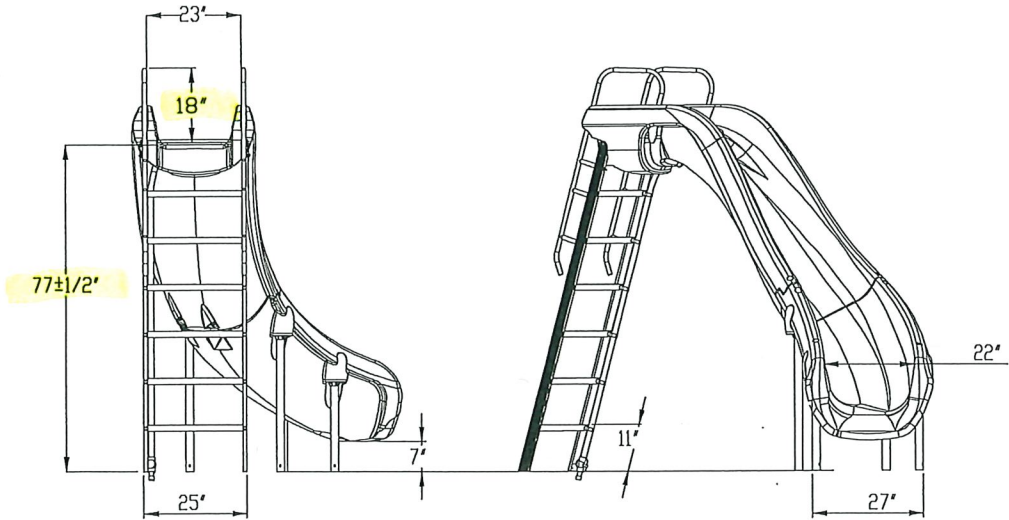

FIGURE A

ROGUE 2 right curve slide shown, left curve is mirror image of right curve.

See Appendices for additional slide layout details.

# MANUFACTURER'S PLACEMENT INSTRUCTIONS

THE SLIDE OWNER MUST REVIEW THE MANUFACTURER'S PLACEMENT INSTRUCTIONS WITH THE INSTALLER TO ENSURE THAT THE MANUFACTURER'S INSTALLATION REQUIREMENTS HAVE BEEN MET.

PROPER ASSEMBLY, INSTALLATION, USE AND SUPERVISION IS ESSENTIAL FOR PROPER OPERATION AND TO REDUCE THE RISK OF SERIOUS INJURY OR DEATH.

1. The critical dimensions for placement of the heliX™ are as shown in FIGURES 2 and 3.
  - A. The slide exit runway surface shall not exceed 20" (508 mm) above the water surface as shown in FIGURE 2.
  - B. The slide shall be positioned so that all water flowing off the runway exit drops into the pool. Recommended overhang is 4" (102 mm).
  - C. The minimum depth of water below the exit lip of the slide shall be 3' (914 mm) and increases to 4'-6" (1372 mm) at Pt. A, which is a distance of 4'-6" (1372 mm) from the exit lip of the slide as shown in FIGURE 2.
  - D. A minimum depth of 4'-6" (1372 mm) shall be maintained at a distance of 9' (2743 mm) along the extended centerline of the slide from Pt. A. as shown in FIGURE 2.

**FIGURE 2**

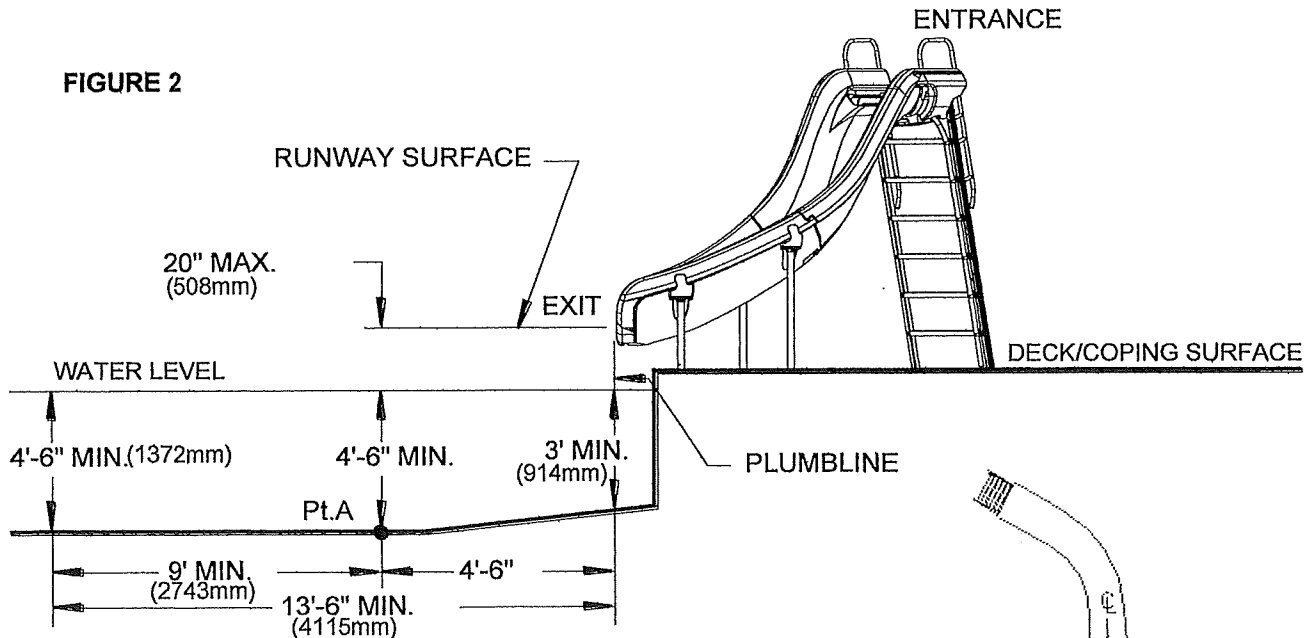

Dimensions are in feet/inches and (millimeters)

2. A minimum clearance area in front of the slide shall be maintained at all times as follows:

The minimum clearance distance on either side of the extended centerline of the slide runway shall not be less than 3'-6" (1067 mm) at a point no less than 2'-6" (762 mm) from the exit lip of the slide and extending a distance of 13'-6" (4115 mm) in front of the slide as shown in FIGURE 3.

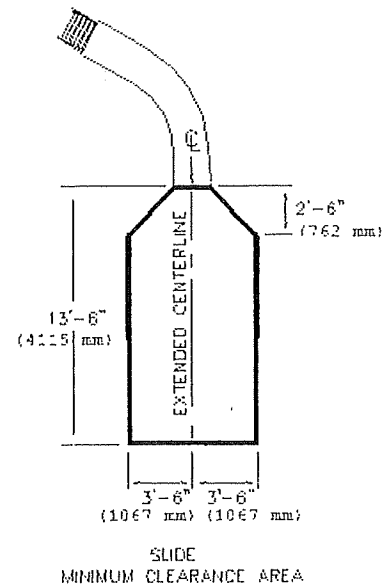

**FIGURE 3**

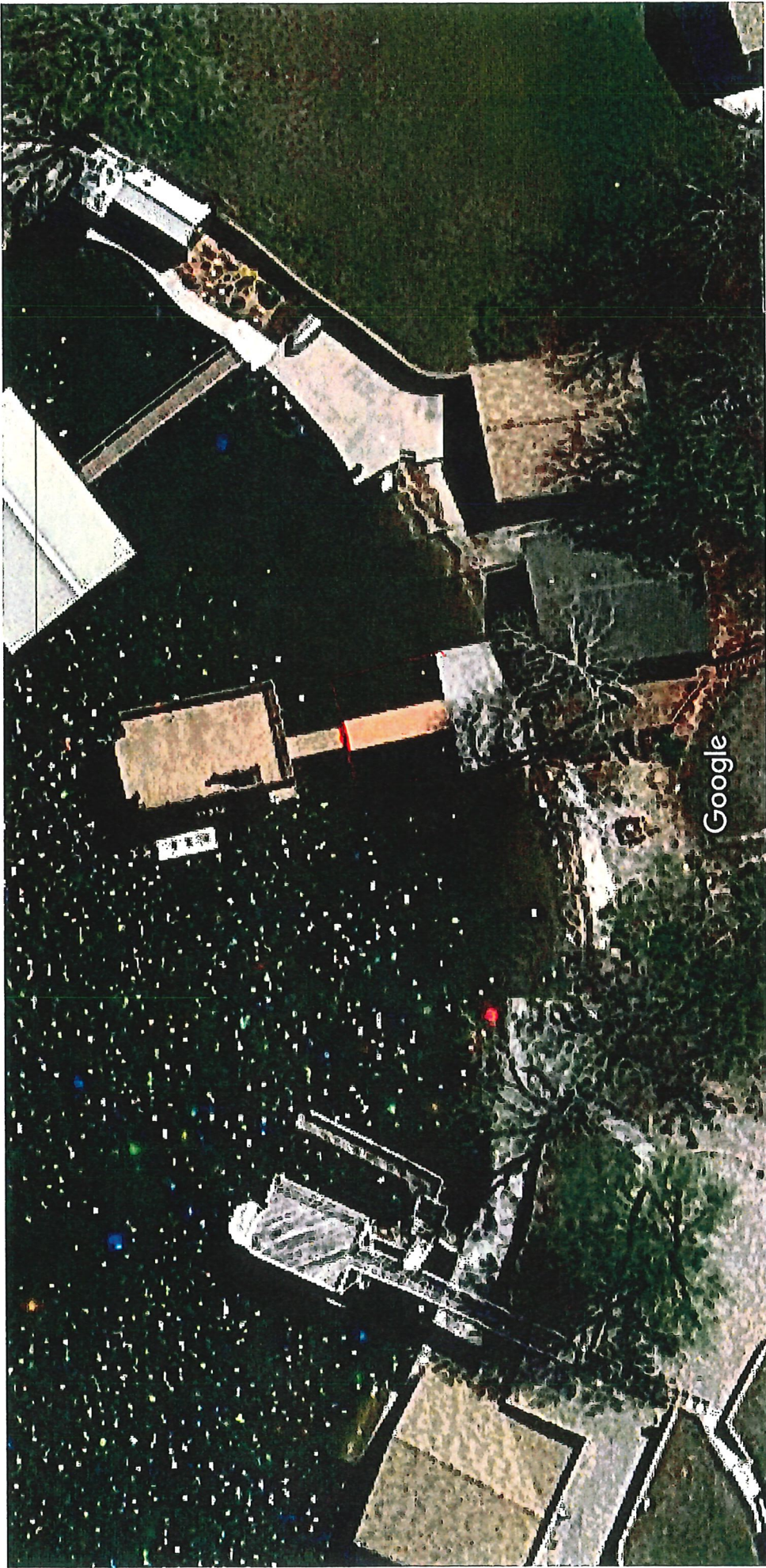

Map data ©2022, Map data ©2022 Google 20 ft